

ONLY FOR MACHINE WITH PROBE THERMOSTATS

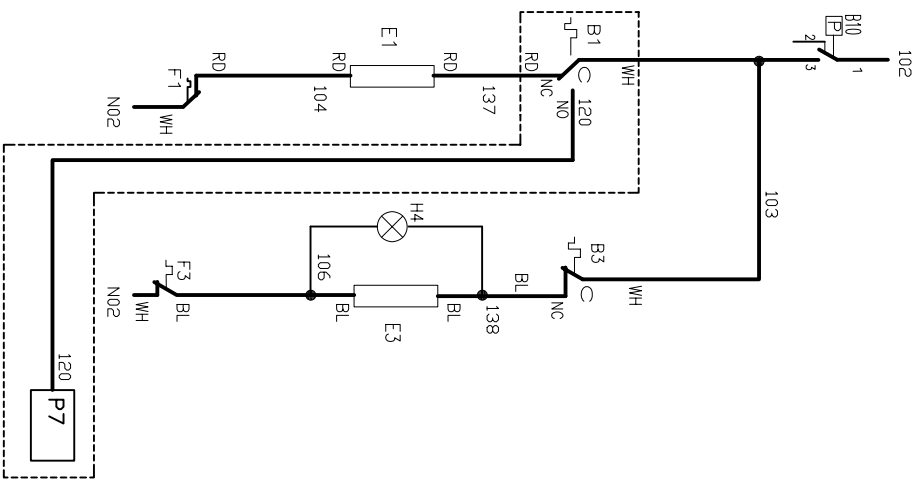

THERMOSTOP ON

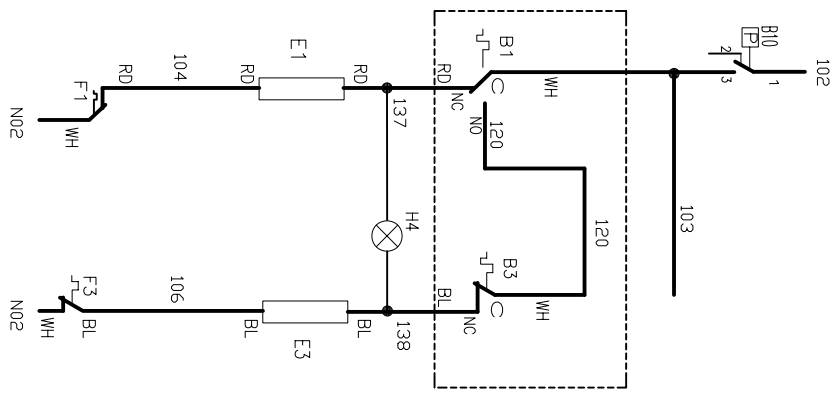

NO SIMULTANEOUSLY
NO RESISTANCES

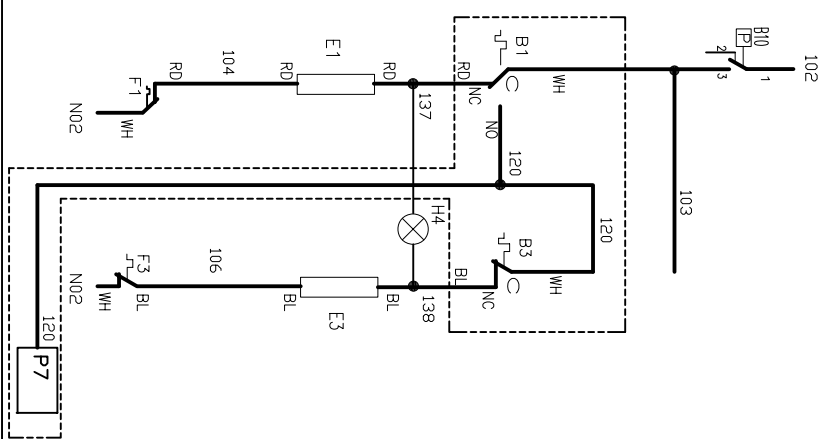

THERMOSTOP ON
NO SIMULTANEOUSLY
NO RESISTANCES

DESCRIZIONE	SOSTITUISCE
	DATA

code Machine -----		denomination		Code	
re-examined	date	WIRING DIAGRAM		1078	
inspected by	date				
validated by	date	total Blat	N° Blat	Next Blat	n°/file
Bertolini	19/11/09	4	2	-	1078a
					mod
					-4

01 02 03 04 05 06 07 08 09 10 11 12 13 14 15 16 17 18

*** OPTIONAL**

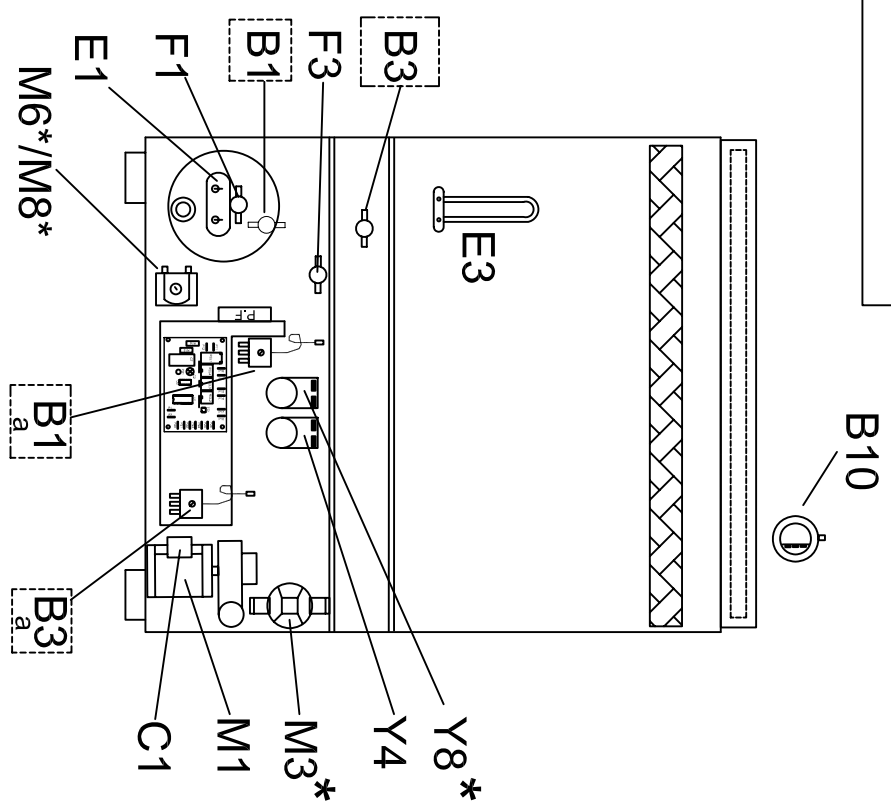

-THERE ARE TWO TYPES OF THERMOSTATS:
 1)THE PROBE THERMOSTATS (B1a/B3a);
 2)THE CONTACT THERMOSTATS (B1/B3);
 -IN THE MACHINE USE ONE OR OTHER.

Front panel type 1

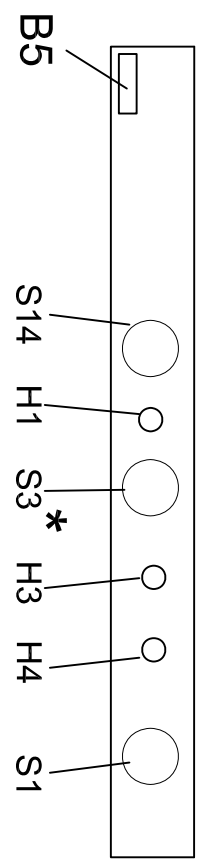

Front panel type 2

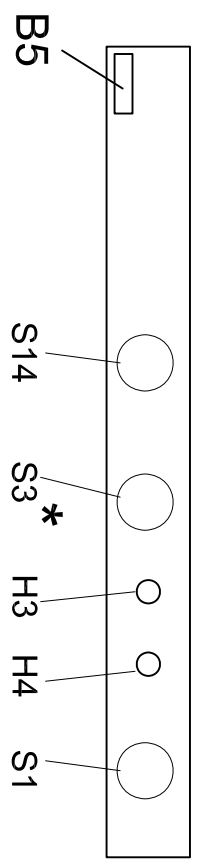

Front panel type 3

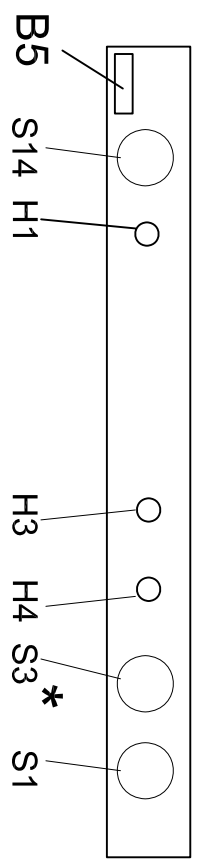

nr MODIFICA	DESCRIZIONE	SOSTITUISCE	DATA
-1			
-2			

code machine	---	denominazione	Code
re-examined	date	TOPOGRAPHIC	1078
inspected by	date		
Bartholdi	19/11/09		
validated by	date		
	19/11/09		
	operator	number	number
	4	3	.
			nr file
			1078T
			mod
			-4

	GB	D	F	I	E	P
B1	Boiler thermostat	Temperaturbegrenzer Durchlauferhitzer	Thermostat surchauffeur	Termostato boiler	Termostato del calderin	Regolador de temperatura caldeira
B3	Tank thermostat	Tanktemperaturbegrenzer	Thermostat cuve	Termostato vasca	Termostato del deposito	Regolador de temperatura tanque
B5	Door switch	Reed- Türsicherheitkontaktschalter	Micro contact de porte	Micro porta	Interruptor de puerta	Micro-interruptor porta
B10	Tank level control	Tankniveauschalter	Pressostat de cuve	Controllo livello vasca	Interruptor del nivel en la cuba	Interruptor de nivel tanque
C1	Wash pump noise filter	Fünkenstörfilter Umwälzpumpe	Condensateur pompe de lavage	Condensatore pompa lavaggio	Condensador bomba de lavado	Condensador bomba lavagem
E1	Boiler heating element	Heizkörper Durchlauferhitzer	Resistance du surchauffeur	Resistenza boiler	Resistencia del calderin	Resistências caldera
E3	Tank heating element	Tankheizung	Resistance de cuve	Resistenza vasca	Resistencia de la cuba	Resistência cuba
F1	Boiler safety thermostat	Durchlauferhitzer Temperaturbegrenzer	Thermostat securite surchauffeur	Termostato sicurezza boiler	Limitador de temperatura del calderin	Rgolador de temperatura caldera
F3	Tank safety thermostat	Tanktemperaturbegrenzer	Thermostat securite cuve	Termostato sicurezza vasca	Limitador de temperatura del deposito	Rgolador de temperatura tanque
H1	Power lamp	Netz Kontrolleuchte	Voyant reseau	Spia di linea	Lámpara de piloto alimentación	Lâmpada indicadora tenção
H3	Cycle lamp	Spülprogramm Kontrolleuchte	Voyant de cycle	Spia ciclo	Lámpara de piloto ciclo	Lâmpada indicadora ciclo
H4	Heating lamp	Heizkörper Kontrolleuchte	Voyant de chauffage	Spia riscaldamento	Lámpara de piloto calefacción	Lâmpada indicadora aquecimento
M1	Wash pump motor	Motor Umwälzpumpe	Moteur pompe lavage	Motore pompa lavaggio	Motor bomba lavado	Motor bomba de lavagem
M3	Drain pump motor	Motor Laugenpumpe	Moteur pompe vidange	Motore pompa scarico	Motor bomba de desagüe	Motor bomba de esgoto
M6	Detergent pump motor	Dosiergerät Reiniger	Moteur pompe produit lavage	Dosatore detergente	Dosificador por el detergente	Doseador de detergente
M8	Rinse aid pump motor	Dosiergerät Glänzmittel	Moteur pompe produit de rinçage	Dosatore brillantante	Dosificador abrillantador	Doseador da solução para brilho
S1	Start cycle push button	START- Taste Spülprogramm	Poussoir mise en cycle	Pulsante avvio ciclo	Pulsador de principio ciclo	Botões arranque ciclo
S3	Drain push button	Taste Laugenpumpe (Entleeren)	Poussoir pompe vidange	Pulsante pompa scarico	Pulsador bomba de desagüe	Botões bomba de esgoto
S14	Machine main switch	Umschalter Betriebs / Ruhestellung - Regenerieren	Sélecteur lavage / arrêt - regeneration	Deviatore servizio / riposo- rigenerazione	Conmutadore conex. / desconex - regeneración	Comutador arranque / interrupção- regeneração
Y4	Fill / hot rinse solenoid valve	Elektromagnetventil Füllen / Klarspülung warm	Electrovanne remplissage	Elettrovalvola carico / risciacquo caldo	Válvula magnetica de entrada / enjuague caliente	Válvula magnetica de entrada / enxague quente
Y8	Regeneration solenoid switch valve	Regenerieren Elektromagnet wechsventil	Electrovanne échangeur régénération	Elettrovalvola scambiatrice di rigenerazione	Válvula cambiadora de regeneración	Válvula cambista de regeneração